



# PSDC05125T

v.1.0

## PSDC 12V/5A/5x1A/TOPIC Switched mode power supply for CCTV.

EN

Edition: 2 from 25.02.2013

Supersedes the : 1 from 08.01.2013 edition



## Features:

- supply output 5x 1A/12V DC
- output voltage adjustment 12V÷ 15VDC
- 5 outputs protected with 1A fuses
- wide range of supply voltage 85÷264VAC
- high efficiency 80%
- LED indication
- protections:
  - SCP short-circuit protection
  - OVP over voltage protection
  - surge protection
  - OLP overload protection
  - warranty – 1 year from the production date

## CONTENTS:

### 1. Technical description.

#### 1.1 General description

#### 1.2 Block diagram

#### 1.3 Description of PSU components and connectors

#### 1.4 Specifications

### 2. Installation.

#### 2.1 Requirements

#### 2.2 Installation procedure

### 3. Operating status indication.

#### 3.1 LED indication

### 4. Operation and use.

#### 4.1 Overload or short circuit at the PSU output

#### 4.2 Maintenance

## 1. Technical description.

### 1.1 General description.

The stabilized PSU **PSDC05125T** is intended for supplying CCTV devices requiring stabilised voltage of **12V DC**. The output voltage adjustment range is adjusted via a potentiometer within the range of **12,0V÷15,0V DC**. The PSU features 5 outputs protected independently by glass fuses.

A failure (a short circuit) in the output circuit makes a fuse blow or an activation of the fuse and disconnection of the circuit from the DC power supply (+U). The PSU is housed in a metallic enclosure with an indication panel.

### 1.2. Block diagram. (fig.1).

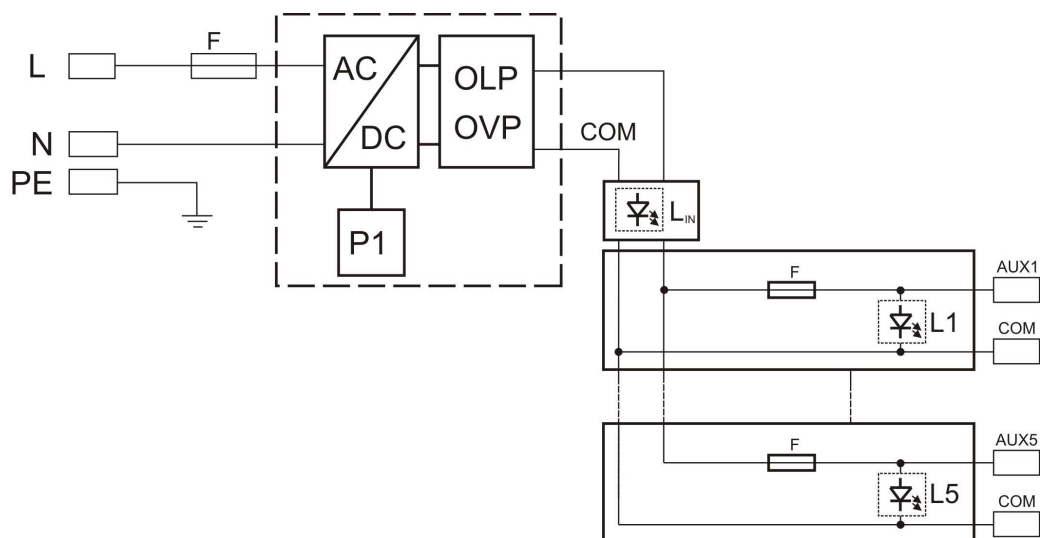

Fig.1. Block diagram of the PSU.

1.3. Description of PSU components and connectors.

Table 1. Elements of the PSU pcb (see fig. 2).

Element no.	Description
[1]	L1.....L5 (green) LEDs (indicating fuse activation)
[2]	F1...F5 glass fuses in AUX (+) circuits
[3]	IN supply input of the LB5 strip
[4]	AUX1.... AUX5 outputs, COM (-) shared terminal

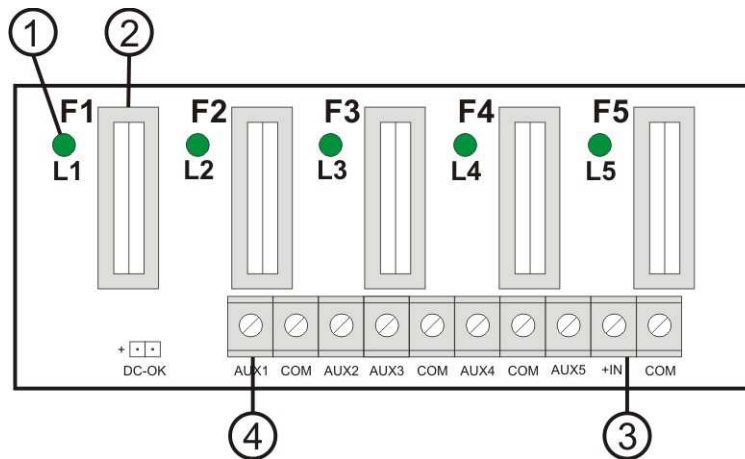

Fig.2. The view of the PSU's pcb.

Table 2. Elements of the PSU (see fig. 3).

Element no.	Description
[1]	L-N 230 V AC power connectors, PE protection connector
[2]	PSU module
[3]	V <sub>ADJ</sub> , potentiometer, output voltage adjustment within the range of 12,0V÷15,0V DC
[4]	LED indication of DC power status, main module of the PSU
[5]	LB5 fuse strip, with power outputs and LED indication

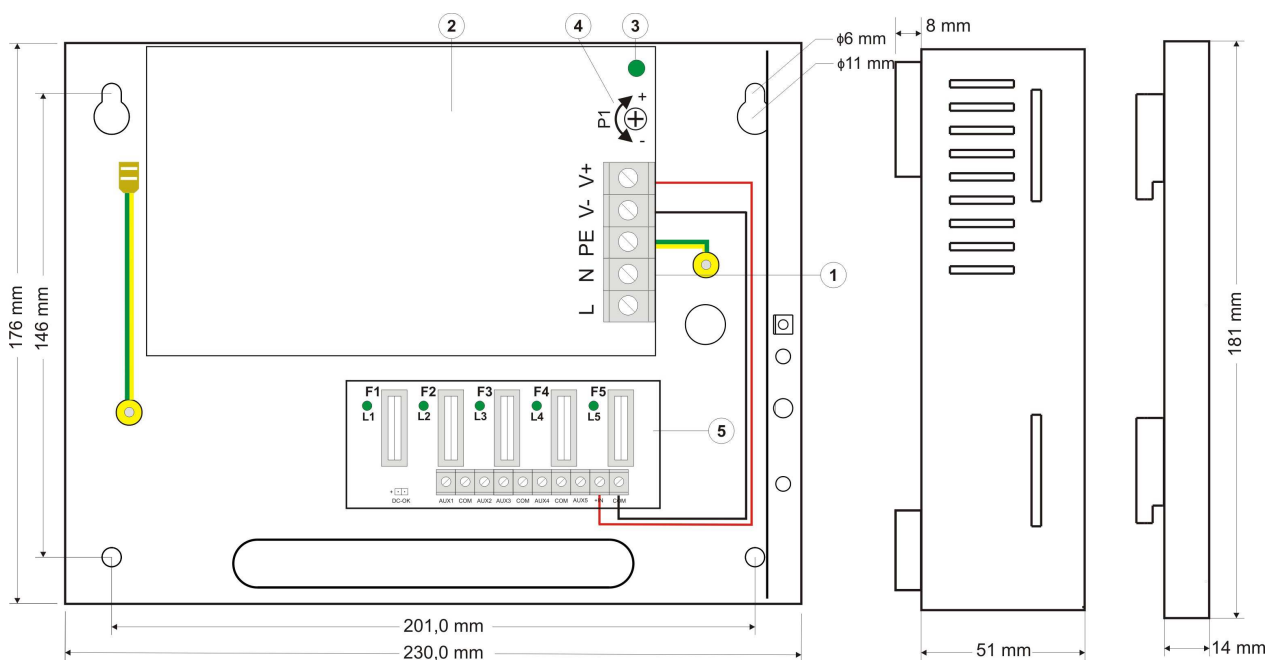

Fig.3. The view of the PSU.

**1.4. Specifications:**

- electrical specifications (tab.3)
- mechanical specifications (tab.4)
- operation safety (tab.5)
- operating specifications (tab.6)

**Electrical specifications (tab. 3).**

Supply voltage	85 ÷ 264V AC
Current consumption	0,6A @230VAC max.
PSU power	60Wmax.
Efficiency	80%
Output voltage	12V DC
Output current	5x 1A ( $\Sigma I = 5A$ ) max. @12V
Output voltage adjustment range	12V ÷ 15VDC
Ripple voltage	100mV p-p max.
Short-circuit protection SCP	LB5 STRIP 5x F 1A fuse PSU MODULE 105% ÷ 150% of PSU power, electronic current limiting
Overload protection OLP	105% ÷ 150% of PSU power, electronic current limiting
Surge protection	varistors
Overvoltage protection OVP	>16V (automatic recovery)
F1 ÷ F5 fuses	F 1A/250V

**Mechanical specifications (tab. 4).**

Enclosure dimensions	230 x 176 x 59 (235 x 181 x 51+8) (WxHxD) [mm] (+/- 2)
Fixing	201 x 146 x 4 szt. $\Phi$ 6 (WxH)
Net/gross weight	1,30/1,45 kg
Enclosure	Steel plate, DC01 0,7mm colour: RAL 9003
Closing	Cheese-head screw: at the front
Connectors	Power supply: 230V AC: $\Phi$ 0,63-2,05 (AWG 22-12) AUX outputs: $\Phi$ 0,51- 2,05 (AWG 24-12) LB5: $\Phi$ 0,51- 2,05 (AWG 24-12)
Notes	The enclosure does not adjoin the assembly surface so that cables can be led. Convictional cooling.

**Operation safety (tab.5).**

Protection class PN-EN 60950-1:2007	I (first)
Protection grade PN-EN 60529: 2002 (U)	IP20
Electrical strength of insulation: - between input (network) circuit and output circuits of the PSU (I/P-O/P) - between input circuit and PE protection circuit (I/P-FG) - between output circuit and PE protection circuit (O/P-FG)	3000V/AC min. 1500V/AC min. 500V/AC min.
Insulation resistance: - between input circuit and output or protection circuit	100 M $\Omega$ , 500V/DC

**Operating specifications (tab.6).**

Operating temperature	-10°C...+50°C
Storage temperature	-25°C...+60°C
Relative humidity	20%...90%, without condensation
Vibrations during operation	unacceptable
Impulse waves during operation	unacceptable
Direct insolation	unacceptable
Vibrations and impulse waves during transport	PN-83/T-42106

## 2. Installation.

### 2.1 Requirements.

The stabilized PSU is to be mounted by a qualified installer, holding relevant permits and licenses (applicable and required for a given country) for 230V/AC interference and low-voltage installations. The unit should be mounted in confined spaces, in accordance with the 2nd environmental class, with normal relative humidity (RH=90% maximum, without condensation) and temperature from -10°C to +50°C. The PSU shall work in a vertical position that guarantees sufficient convectional air-flow through ventilating holes of the enclosure.



**During normal operation the total current consumption of the receivers cannot exceed  $I=5A$**

As the PSU module is designed for a continuous operation and is not equipped with a power-switch, therefore an appropriate overload protection shall be guaranteed in the power supply circuit. Moreover, the user shall be informed about the method of unplugging (most frequently through separating and assigning an appropriate fuse in the fuse-box). The electrical system shall follow valid standards and regulations.

### 2.2 Installation procedure.

1. **Before installation, make sure that the voltage in the 230V power-supply circuit is cut off.**
2. Mount the PSU in a selected location and connect the wires.
3. Connect the power cables (~230VAC) to L-N terminals of the PSU. Connect the ground wire to the terminal marked by the earth symbol. Use a three-core cable (with a yellow and green PE protection wire ) to make the connection. Lead the cables to the appropriate terminals of the connection board through the bushing.



**The shock protection circuit shall be performed with a particular care, i.e. the yellow and green wire coat of the power cable shall stick to one side of the terminal marked with the , earth symbol in the PSU enclosure. Operation of the power supply without a properly made and fully operational shock protection circuit is UNACCEPTABLE! It can result in device damage or an electric shock.**

4. Connect the receivers' cables to the **AUX1...AUX5** connectors on the **LB5 strips**.
5. In electrical installations with significant voltage drops in the resistance of the wires that lead to the receivers, the voltage value can be corrected with the P1 potentiometer (12,0V÷15,0V DC).
6. Check the PSU operating status indication
7. Once the installation and operation control have been completed, the enclosure can be locked.

## 3. Operating status indication.

The PSU is equipped with LED indication of operation status. The presence of power at the outputs of the PSU is indicated by the illumination of green LEDs on the front panel of the device.

### 3.1. LED indication

- **LED1...LED5** green diodes indicate power at the outputs:  
LB5- AUX1.....AUX5.

In case of a power loss at the output (fuse activation), an appropriate diode goes out. (L1 for AUX1, L2 for AUX2 etc.)

## **4. Operation and use.**

### **4.1 Overload or short circuit at the PSU output.**

The AUX1 ÷ AUX5 PSU outputs of the LB5 strips are protected against a short circuit by glass fuses. If a fuse-assisted protection has been chosen, replace the fuse (of the same parameters) in case of a failure.

### **4.2 Maintenance.**

Any and all maintenance operations may be performed following the disconnection of the PSU from the power supply network. The PSU does not require performing any specific maintenance measures. However, in case of significant dust level, clean its interior with compressed air. In case of a fuse exchange, use the replacement of the same parameters.

**WEEE MARKING**

**According to the EU WEE Directive – It is required not to dispose of electric or electronic waste as unsorted municipal waste and to collect such WEEE separately.**

**GENERAL WARRANTY CONDITIONS**

1. Pulsar K. Bogusz Sp.j. (the manufacturer) grants a one-year warranty for the equipment, counted from the device's production date.
2. The warranty includes free-of-charge repair or replacement with an appropriate equivalent (the selection is at the manufacturer's discretion) if the malfunction is due to the manufacturer, includes manufacturing or material defects, unless such defects have been reported within the warranty period (item 1).
3. The equipment subject to warranty is to be brought to the place where it was purchased, or directly to the main office of the manufacturer.
4. The warranty applies to complete equipment, accompanied by a properly filled warranty claim with a description of the defect.
5. Should the claim be accepted, the manufacturer is obliged to provide warranty repairs, at the earliest convenience, however not later than within 14 days from the delivery to the service centre of the manufacturer.
6. The repair period mentioned in item 5 may be prolonged, if there are no technical possibilities to carry out the repairs, or if the equipment has been conditionally accepted, due to the breaking warranty terms by the claimant.
7. All the services rendered by force of the warranty are carried out at the service centre of the manufacturer, exclusively.
8. The warranty does not cover the defects of the equipment, resulting from:
  - reasons beyond the manufacturer's control,
  - mechanical damage,
  - improper storage and transport,
  - use that violates the operation manual or equipment's intended use
  - fortuitous events, including lightning discharges, power failures, fire, flood, high temperatures and chemical agents,
  - improper installation and configuration (in defiance with the manual),
9. The warranty is void in any of the following circumstances:
  - construction changes
  - repairs carried out by any unauthorized service center
  - damage or removal of warranty labels
  - modifications of the serial number
10. The liability of the manufacturer towards the buyer is limited to the value of the equipment, determined according to the wholesale prices suggested by the manufacturer on the day of purchase.
11. The manufacturer takes no responsibility for the defects that result from:
  - the damaging, malfunctioning or inability to operate the equipment
  - defects that result from using the equipment outside its stated specifications and operating parameters failing to abide by the recommendations and requirements contained in the manual, or the use of the equipment.

**Pulsar K. Bogusz Sp.j.**

Siedlec 150, 32-744 Łapczyca, Poland  
Tel. (+48) 14-610-19-40, Fax. (+48) 14-610-19-50  
e-mail: [biuro@pulsar.pl](mailto:biuro@pulsar.pl), [sales@pulsar.pl](mailto:sales@pulsar.pl)  
http:// [www.pulsar.pl](http://www.pulsar.pl), [www.zasilacze.pl](http://www.zasilacze.pl)